



## **DS Series Solar System**

### **Permit information**



**Consol 30-58-1800 Collector Frame mount on Butynol roof  
Valve vent, Open loop**

# CONSOL NEW ZEALAND LTD

---

**This system is an evacuated tube system coupled to a stainless steel cylinder with an open loop circuit that is valve vented.**

## **Brief Description**

- **Consol New Zealand is a Full member of the Solar Industries Association and is accredited for Supply and Installation.**
- **The Consol system is ASNZS 2712:2007 STANDARDS APPROVED. (See attached certificate)**
- **The Consol system is an EECA approved system and is part of the Energy wise program.**
  
- **The panel is 2450mm wide by 1890mm high**
- **The light weight panel is 20 kg/m<sup>2</sup> and is fixed to the roof with rubber blocks to create an air space of 20mm between the frame and the roof.**
- **The manifold and frame for mounting is manufactured from powder coated Aluminum, the tubes are borosilicate glass and fixings are galvanized.**
- **All pipe work on the solar circuit is 15mm copper insulated with 13mm wall Armaflex FR. All external insulation is wrapped to protect it from the elements.**
- **Legionella is controlled by pumped circuit and auxiliary heating.**
- **Consol Solar systems are to be installed only by Accredited installers.**

**PUMP CONTROLLER:** The controller runs the system, measures temperatures at the cylinder and manifold via temperature probes. This enables the controller to decide the optimal time to start the pump to transfer the heated fluid from the manifold to the cylinder. Power supply to the controller and pump are not to be on a circuit that is controlled by the electricity supplier.

The pump controller protects the system against freezing and overheating. The operation instructions for the controller clearly outline the functions and settings of the system and need to be used in conjunction with the set up and future operation of the system.

The controller for this system requires three probes for accurate operation. Probe location is outlined in the controller operation and installation manual. Probe pockets are to be dry before inserted.

A separate instruction manual for the controller is supplied.

## **SUPPLEMENTARY HEATING CONTROLLER:**

The controller manual also outlines the programming of the timing heating parameters necessary for efficient operation and should be followed.

This is very important as the cylinder temperature must reach 60 degrees once a day to control the growth of Legionella which is harmful to your health.

# CONSOL NEW ZEALAND LTD

---

**PUMP:** The pump is the means of transferring the heated fluid from the manifold to the cylinder and the cooler fluid from the cylinder to the manifold to be heated. The pump is operated by the controller and needs a continuous supply of power to allow frost protection of the system. This should be prominently displayed. The pump should draw the coldest water from the bottom of the tank and return at a higher point using the connection points recommended by the manufacturer. The pump when mounted securely must be above the cylinder safe tray in case of leakage. An isolation valve is to be located either side of the pump to enable ease of removal for servicing.

The pump has three settings and a flow meter is to be used to enable the correct flow rate (30 liters/hr/ m<sup>2</sup> of collector area). The controller manual outlines the settings for the pump and controller operation and changing these settings will affect the performance of the system.

**Valves :** The valves associated with the solar system are necessary for protection, operation and maintenance of the system. The necessary valves are outlined in the schematic drawings of the plumbing diagrams. If draining cylinder

# CONSOL NEW ZEALAND LTD

---

for maintenance of valves disconnect all electrical to the cylinder.

- A. Pressure created by the system will be relieved through the cold water expansion and temperature pressure relief on the cylinder. Easing of valves to be carried out by a registered craftsman plumber. Tempering valve is necessary to reduce the water to a safe temperature.
- B. Air relief valve at the highest point of the pipe work. Use only CALEFFI SOLAR AIR RELIEF 250031. Rated to 180 degrees Celsius and 10 Bar.
- C. Non return valve on the inlet line and out let line of the collector, to and from the cylinder.
- D. Two shut off valves either side of the pump.

## **E. Pipeline and insulation.**

- a. Use copper pipeline no less than 15 mm.
- b. Use long radius bends to reduce resistance to flow rates. Pipe work is to be flushed of foreign material.
- c. Pipe work to be pressure tested to 1.5 times the maximum working pressure prior to insulating.
- d. Insulation of the solar pipe work to be Armaflex FR.
- e. External insulation to be foil covered to reduce degradation from the elements.
- f. Length of pipe work should be kept to a minimum to reduce the time for completing fluid transfer.
- g. Long pipe runs should incorporate expansion loops, horizontally formed to avoid air locks

# CONSOL NEW ZEALAND LTD

h. Insulation material, insulation thickness and operation method should comply with regional regulation.

**Water Tank:** The Coopers solar ready cylinder is constructed of Duplex stainless steel and is the integral part of the solar package.

The cylinder comes with the temperature and pressure relief valve that must be installed. Cylinders will be placed on a safe tray with a 40mm waste if in a location that leakage could cause damage to property.

## System Tech-parameters

Manifold: unitary aluminum alloy manifold Thickness:1.9mm
Material of bracket: aluminum alloy 1.9mM
Material of Heater Pipe: T2 copper
Insulation material: rock wool Thickness of rock wool: 96mm
Density of rock wool: 80kg/m3
Seal: silicon rubber
Hydraulic connections: copper pipe
Max. operation pressure: 8 bar
Test pressure: 10 bar
Max. working temperature: 220°
Min. working temperature:-40°
Max. tilt angle: 45 °
Min. tilt angle: 15°
Thickness of water carrying tube: 0.8mm
Surface finish: powder coated
Permissible wind: 45m/s
Snow load: < 0.6 kpa

# CONSOL NEW ZEALAND LTD

PARAMETER	
Water heater model number:	Consol D 30-58-1800 with the MP 300 CYLINDER
Date of AS/NZS2712 compliance approval	2007

<i>Information about the cylinder used</i>			
Cylinder Manufacturer	H J Cooper Ltd		
Cylinder model number	MP180	MP250	MP300
Cylinder Physical (total) Volume	180L	250L	300L
Cylinder Rated Volume (if known)	180	250	300
Cylinder MEPS Rated	YES		
Cylinder standing heat-loss (kWh/day at $(T_{cyl}-T_{amb})=55^{\circ}\text{C}$ )	180L-1.13	250L-1.59	300L-1.76
Test Lab for standing heat-loss Date of test	23/07/05	10/08/05	23/07/05
Cylinder Inner Diameter	448mm		
Cylinder Wall Overall Thickness (include all wall components, i.e. glass lining if applicable, inner metal shell, insulation, outer metal shell)	1.0mm #2304 Duplex stainless steel		
Cylinder Wall Components' materials and individual thicknesses (here should be given the individual thicknesses of the wall components mentioned above)	N/A		
Thickness of insulation and type of foam	50MM Nominal , exp poly		
Number of Elements in cylinder	1 Standard with 2 <sup>nd</sup> optional		
Element power rating (in kW)	3 kw	3 kw	
Height of element 1 from bottom of cylinder	Element dips down to 100 mm from the bottom of the cylinder		
Electricity tariff element 1 is connected to.	Night rate		
Height of element 2 from bottom of cylinder	1076mm		
Electricity tariff element 2 is connected to.	Day / Night rate		
Height of Thermostat 1 above the bottom of the cylinder	335mm		
Height of Thermostat 2 above the bottom of the cylinder	1076mm		
Thermostat temperature difference between ON/OFF (temp dead band)	+/- 5degrees c		

# CONSOL NEW ZEALAND LTD

Thermostat set point (1)	65 degrees c
Thermostat set point (2)	65 degrees c
Height of Cold Sensor above the bottom of the cylinder	340 mm
Does the Cylinder have an internal Enamel layer?	no
If yes, what is the thickness of enamel layer	n/a
Height of hot water draw-off port on side of cylinder from bottom of cylinder.	1726mm
Height of inlet of dip tube connected to hot water draw-off port if there is one.	n/a
Height of cold water (mains) entry into the cylinder (from the bottom of cylinder)	5mm
<b><i>Information about the auxiliary boost controller</i></b>	
Controller temperature difference between ON/OFF (dead band) (if electronic thermostat used)	Range 2 degrees – 15 degrees default valve is set at 8 degrees
Timer settings (if timer used) for each element	3 timer settings morning noon and night
Hold-off timer settings (if used)	Controller timer based hold off
Frost protection settings (if used)	Frost protection range 2 degrees to 10 degrees
Other controller functions (if used)	High temperature protection, Temperature difference circulation, Timer controlled circulation, Temperature controlled circulation, Temperature controlled auxillary heating settings.
<b><i>Information about the solar collector</i></b>	
<b>Solar collector model no.</b>	
Type of collector	Evacuated tube system
Tested to the standard AS 2535 This test gives the panel efficiency used in the Australian RECs scheme.	SPF TEST REPORT
Collector gross area	4.725m <sup>2</sup>
Collector aperture area	2.833m <sup>2</sup>
Collector absorber area	2.429m <sup>2</sup>
Weight of collector loaded with fluid	98kg
Collector glass type	Bronsilicate
Absorber type, and material bonded on to (eg black paint on copper)	Al ni AL



# CONSOL NEW ZEALAND LTD

Collector inlet pipe inner diameter	20mm
Collector outlet pipe inner diameter	20mm
<b>Information specific to evacuated tube collectors</b>	
Heat pipe length (for Evacuated tube systems)	1723
Header length	2450mm
Header inner diameter (for Evacuated tube systems)	33mm
Insulation material used for the header	Rock wool
How is heat transferred from the glass tube to the header / cylinder	Via a copper endothermic tube that inserts into socket in the manifold
Shape of fin (if used): either describe or sketch.	Hamburger bun shaped aluminum fins.
Reflectors	Individual stainless reflectors that insert between lower side of the tubes. The reflectors cover 80% of the collector area
<b>Information about the differential controller and pump used</b>	
Differential Controller model	SR868C6
Pump supplier and model no.	WILO RS25/6
Pump flow rate	3 SETTINGS OPTIMAL 90 – 110 L/HR
Flow meter used on installation	No
Placement of panel sensor	Placed into socket welded to the insulated manifold
Placement of cylinder sensor 1 (cold) – height above bottom of cyl.	335mm
Placement of cylinder sensor 2 (if used) – height above bottom of cyl.	1397mm
Open or closed circuit	open
<b>Information about the pipe-work between cylinder and panel</b>	
Collector inlet pipe insulation material	centurylon
Collector inlet pipe insulation thickness	25mm
Collector outlet pipe insulation material	centurylon
Collector outlet pipe insulation thickness	25mm
Diameter of piping used (ID)	15mm
Height of hot water draw-off port on side of cylinder from bottom of cylinder.	310
Height of inlet of dip tube connected to hot water draw-off port if there is one.	5mm from bottom of cylinder
<b>General</b>	

# CONSOL NEW ZEALAND LTD

<p>How does the system control stagnation events?</p>	<p>Controller is fitted with a high temperature protection feature. When temperature reaches a set temp the controller opens a valve on the inlet pipe and shuts off the pump. When the tank temp lowers to a set parameter temp the function is deactivated.</p>
<p>How does the system control freezing events?</p>	<p>Frost protection via insulation and programme in the controller to avoid freezing.</p>
<p>What is the maximum temperature the cylinder can withstand? How do you control over-temperature within the cylinder?</p>	<p>Cylinder max temperature is 90 degrees. The controller has a function to stop the cylinder heating at set temperature.</p>

# CONSOL NEW ZEALAND LTD

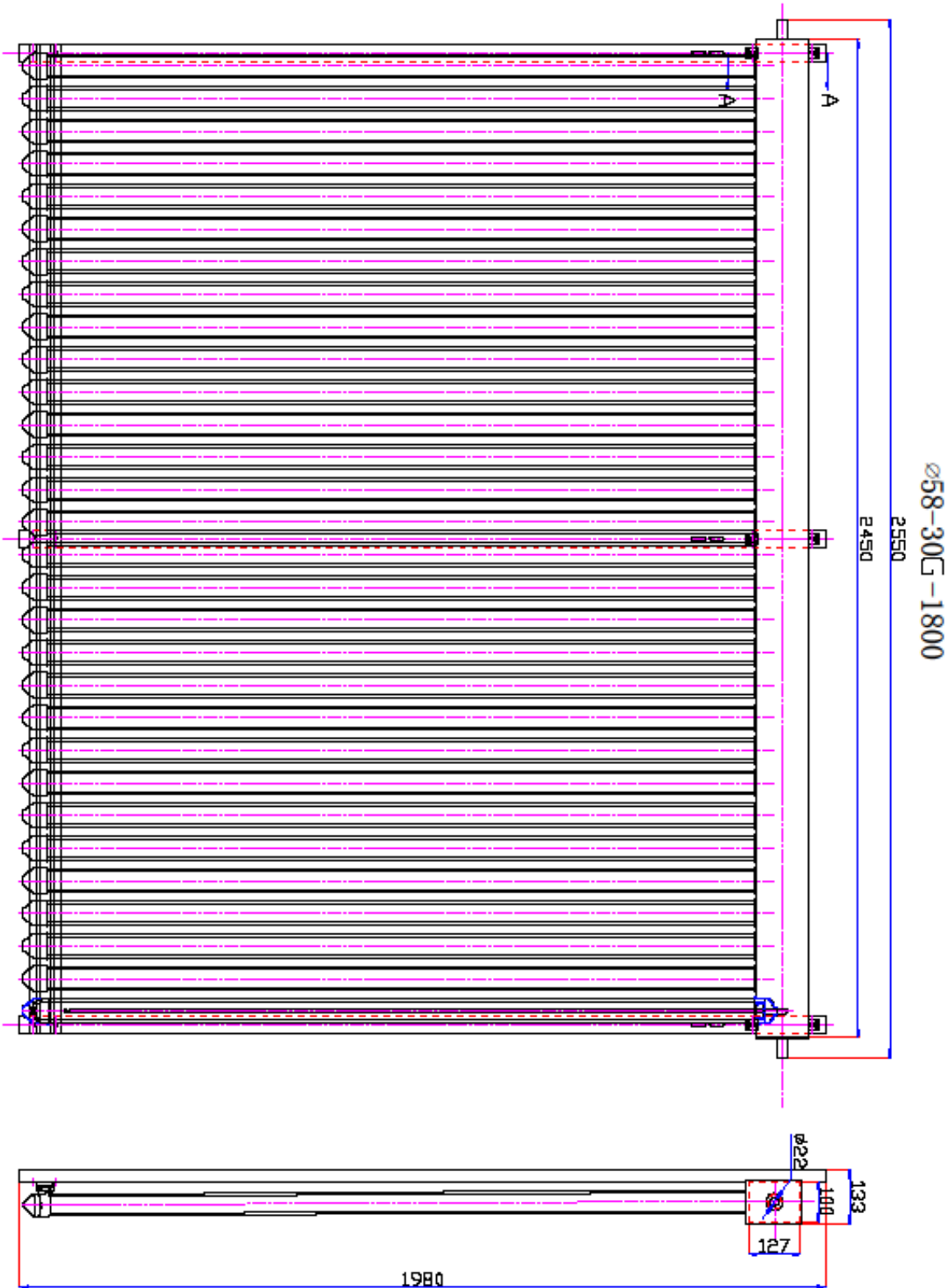

# CONSOL NEW ZEALAND LTD

---

## FIXING

Fixings to be fastened through the top of the corrugations. The frame to be set 20mm off the roof by way of rubber packers at the fixing points. Fixings to be galvanized and securely fixed through the perlin into the roof truss.

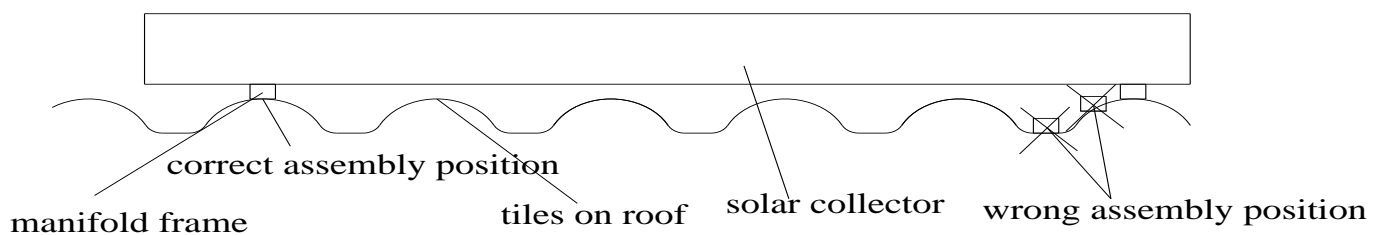

Frame upright can be adjusted by related situation about the roof.

# CONSOL NEW ZEALAND LTD

## INSTALLATION DETAILS CONSOL 'D' SERIES SOLAR COLLECTORS

### BUTYL RUBBER ROOFING

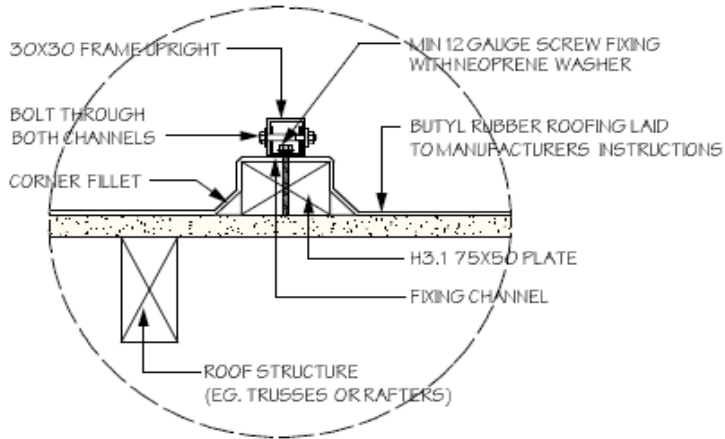

### BUTYL RUBBER ROOFING

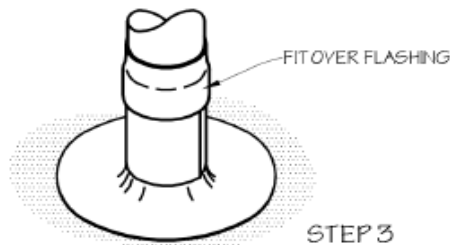
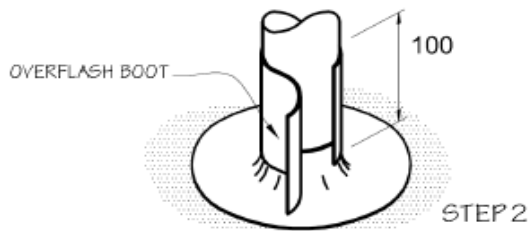
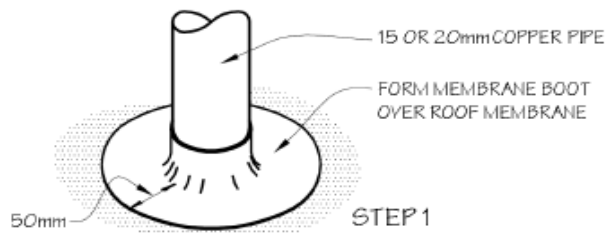

### PIPE PENETRATION FLASHING

## Stand Mounting of collector.

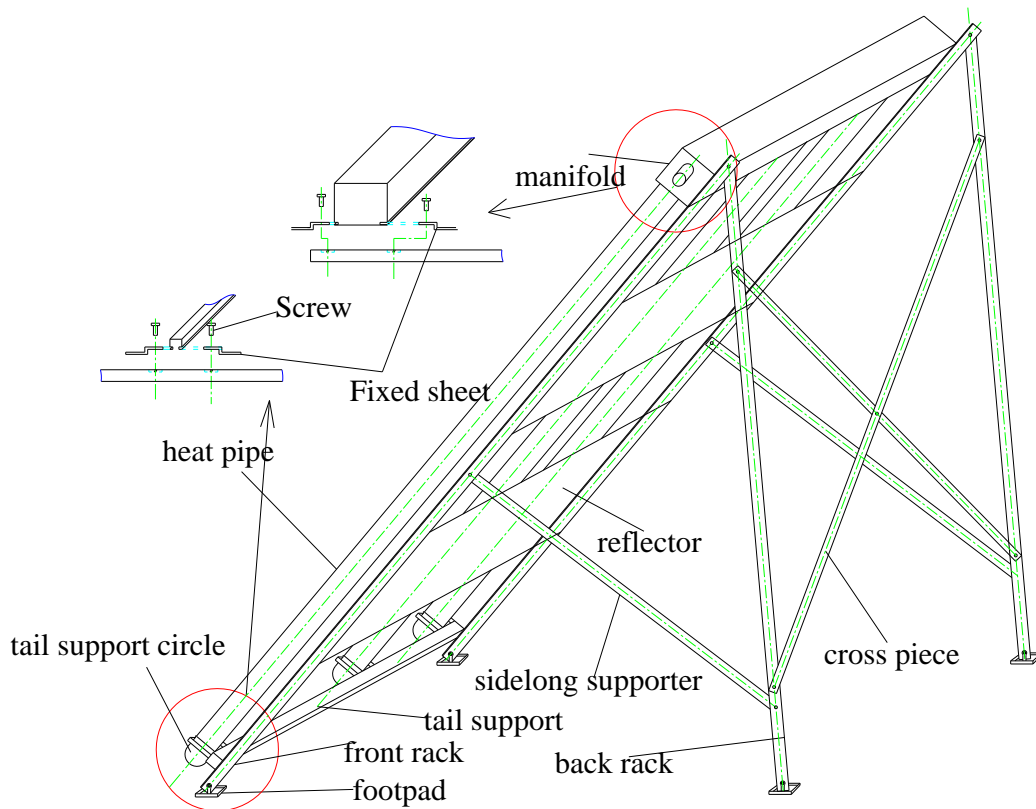

The stand mounted collector may be necessary where the roof is not at the correct inclination.

The customer should be advised that performance is reduced if the panel is not mounted at the correct inclination. The performance can be increased by adding extra tubes as an alternative to mounting on a stand.

## PLUMBING DIAGRAM

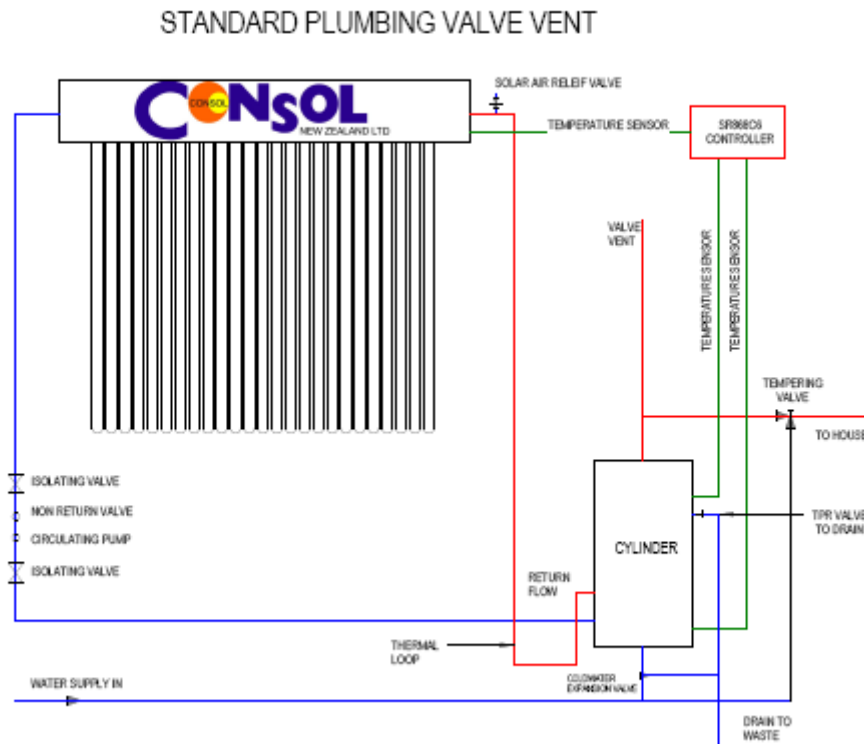

## Connection of Controllers



Installation and commissioning of the controller must be carried out by a registered electrician and in accordance with the operation and instruction manual.

Care should be taken when wiring in the controller auxiliary heating where ripple control could disturb the operation of the system. The adjustment of controllers may adversely affect solar performance.

The controller controls the system components. It will operate the switching time of the cylinder and pump. There needs to be a continuous power supply to the controller as the freeze protection function is operated by the controller. This system operates with three temperature probes that are wired to the collector, cylinder and controller. Placement of the sensors according to the wiring diagrams is important. Sensor cables are to be protected from degradation by weather and animals.

The controller is to be installed in a position that is accessible for servicing.



Connection to the mains is via a plug and is not to be hard wired.

Functions of the controller include

- Temperature difference controlling
- Temperature controlled auxiliary heating
- Time controlled auxiliary heating
- Temperature controlled hot water circulation
- Anti freezing protection
- High temperature protection

## **Connection of Pump**

The pump in this direct system will draw the water from the low point of the cylinder, circulate it through the collector(s) and return the heated water at a point higher than the draw off point.

The pump used in this system is the WILO RS25/6.

The pump will be installed with isolation fittings either side that will allow removal for maintenance or replacement.

This pump is designed to produce the hydrostatic head that may not be suitable for every application.

The pump is wired into and operated by the system controller.

The pump is to be mounted according to the manufacturer's instructions and according to the system layout diagrams.

The pump is fitted to the system by the installer and the wiring is carried

out by the electrician.



### **6.3. Connection of Cylinder**

The chosen cylinder for the Consol system is the Coopers mains pressure stainless steel solar ready M P series.

The cylinder comes standard with element and thermostat and temperature / pressure relief valve set to 850kpa and 90 degrees (the cylinder has a manual resettable cut out button set at 85 degrees).

Cylinders are to be restrained as per building code. Thermostat should be set to 55 degrees or 45 degrees for the elderly and child facilities. The cylinder is to be filled and vented prior to being energized by power or solar.

The cylinder is the storage for the water heated via solar gain and is to be correctly sized according to the water usage and the size of the collector. The cylinder has an electrical element to back up the solar. The electrical element is wired to and is controlled by the controller.

# CONSOL NEW ZEALAND LTD

R



P.O. BOX 687, NELSON,  
NEW ZEALAND

PHONE (03) 547 2847  
FAX (03) 547 2809  
EMAIL: [info@appliedresearch.co.nz](mailto:info@appliedresearch.co.nz)  
WEB: [www.appliedresearch.co.nz](http://www.appliedresearch.co.nz)

Report 10/2266

July 2<sup>nd</sup>, 2010

Page 1/2

Customer: Consol NZ Ltd  
PO Box 36409  
CHRISTCHURCH 8146

P1514/0

Attention: Matt Wheelans

### Compliance Certificate

**Appliance:** Consol NZ Ltd 58-1800 tubo SHW systems

**Standard Applied:** AS/NZS2712:2007

**Full Report Ref.:** 10/2229, 10/2150

Based on the information and results obtained during testing and assessment, the Consol NZ Ltd solar hot water systems comply with the type testing requirements of AS/NZS2712:2007. Systems covered by this certificate are listed below.

This compliance certificate relates only to the product sample tested. Any modifications to the product may invalidate the compliance results.

Our reports 10/2229 and 10/2150 gives details of the appliance, the assessment and the results obtained.

**This report:**

Prepared by: G. Looman

Approved by: W. S. Webley

Release Date:

5-7-10

This report must not be reproduced except in full. Results are based on material and information supplied by the client. Applied Research Services Ltd shall not be liable in respect of any loss or damage (including consequential loss or damage) resulting from the use of reports prepared by them. Results issued in electronic form are subject to confirmation by issue of final written report.

# CONSOL NEW ZEALAND LTD

---



**HJ COOPER Ltd**

130 St Georges Road  
Avondale  
Auckland  
PO Box 15-776, New Lynn.  
Ph: (09) 828-6852 Fax: (09) 828-4134  
Email [jason@hjcooper.co.nz](mailto:jason@hjcooper.co.nz)  
3 March 2010

To whom it may concern

This certifies that duplex stainless steel mains pressure cylinder with heat exchanger made by HJ Cooper Ltd complies with the relevant requirements of NZS4606.1:1989.

The type of cylinder mentioned above is listed on [www.energyrating.govt.au](http://www.energyrating.govt.au).

Yours faithfully

Jason Chen

A handwritten signature in black ink, appearing to read "Jason Chen". The signature is written in a cursive, flowing style.

Production Manager

# CONSOL NEW ZEALAND LTD

---

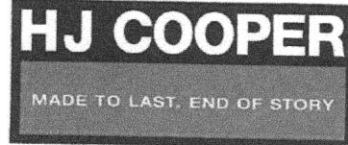

**HJ COOPER Ltd**

130 St Georges Road

Avondale

Auckland

PO Box 15-776, New Lynn.

Ph: (09) 828-6852 Fax: (09) 828-4134

Email [jason@hjcooper.co.nz](mailto:jason@hjcooper.co.nz)

3 March 2010

To whom it may concern

This certifies that the hot water cylinder manufactured by HJ Cooper meets requirements of clause 3.3 of standard AS/NZS 2712:2007.

Yours faithfully

Jason Chen

A handwritten signature in cursive script that reads "Jason Chen".

Production Manager.

# CONSOL NEW ZEALAND LTD

---

## CONTACT:

### CONSOL NEW ZEALAND LIMITED

**Phone: 03 982 0738**

**Fax: 03 982 0739**

**Email: [info@consolsolar.co.nz](mailto:info@consolsolar.co.nz)**

**Web: [www.consolsolar.co.nz](http://www.consolsolar.co.nz)**